

Capacitive Isolated High Precision Analog Signal Isolator

High Precision Isolation Amplifier with EMC Resistance: ISO EC U(A)-P-O series

Features

- EMC Resistant Small Form Factor SIP 12Pin UL94V-0 Flame Retardant Package
- No external potentiometer calibration, no zero and gain adjustments
- Support single-ended input to positive-negative signal and positive-negative to single-ended signal isolation and transmission.
- Accuracy grade: 0.01 grade, 0.1 grade, 0.2 grade
- Very high linearity over the full scale range (non-linearity $\pm 0.01\%$ FSR)
- 0-75mV/0-2.5V/0-5V/0-10V/0- ± 100 mV/0- ± 5 V/0- ± 10 with Mutual isolation, amplification and conversion between 0- ± 20 mA/4-20mA signals.
- 3000VDC triple isolation between auxiliary power supply and signal inputs and outputs
- Auxiliary power supply: 5V/12V/15V/24V DC single power supply
- DIN35 rail-mounted or module soldering mounting on PCB board is optional
- Wide temperature range for industrial grade operating environments: -40 ~ +85 °C

Typical application

- Isolation, conversion and amplification of analog current/voltage signals
- operation monitoring in industrial process control system
- PLC/FCS/DCS Control System Analog Signal Isolation Acquisition
- Isolated amplified control of motor and SCR signals
- Analog signal ground interference suppression and isolated acquisition of each circuit
- Industrial field analog signal isolation and amplification conversion and long line transmission
- Instrumentation and sensors, PLC analog signal transceiver
- High-voltage isolation safety barriers for power monitoring and medical equipment
- Multi-channel intelligent sensor inputs are isolated from each loop and anti-interference
- Sensor voltage/current analog signal 1-input&2-output , 1-input&3-output, 2-input&2-output isolation, amplification, conversion function to achieve

Summarize

SunYuan ISO EC series analog signal isolation amplifiers are capacitively coupled isolation hybrid integrated circuits with strong resistance to EMC interference. The amplifier uses a new modulation - demodulation capacitive coupling isolation technology, the signal in the module in the form of digital signals through the capacitive isolation layer for transmission, through the digital modulation and capacitive coupling isolation to maintain the integrity of the signal, so that the digital signal through the capacitive isolation layer can also provide excellent reliability and superior high-frequency transient immunity.

ISOEC series modules use small volume standard SIP12Pin flame-retardant shell and resin material package, using a single power supply and in the same chip integrated a group of isolated DC/DC converter power supply and a group of capacitively coupled analog signal isolation amplifier. The module supports analog single-ended input to positive and negative signals and positive and negative signals to single-ended signal isolation and transmission function, without external potentiometers and other components, free of zero and gain adjustment, which greatly simplifies the user's design and on-site use of the cost. The internal capacitive isolation technology of the product has better anti-EMC interference capability than the magnetic isolation technology, and better temperature drift characteristics and linearity than the opto-coupler isolation technology, eliminating the need to repeatedly calibrate the zero and fullness of the tedious. The single power supply of the auxiliary power supply and the 3000VDC triple isolation design with signal inputs and outputs allow users to use single or multiple power supplies when using multiple modules at the same time.

ISOEC series modules are simple and easy to use, the product has a PCB board welding and standard DIN 35 rail slot fixed two ways of installation, rail-mounted can be achieved in one into two out, one into three out, two into two out, such as a variety of sensors in the industrial field and instrumentation or control system letter analog signal isolation, distribution, amplification and conversion functions, and to meet the humidity, vibration, and a wide range of temperatures (-40 ~ +85 °C) of the industrial-grade use of the environmental requirements. It has a wide range of applications in the fields of rail voltage monitoring, generator or motor safety operation monitoring, power transmission and distribution remote monitoring, instrumentation and sensor signal transmitting and receiving, medical equipment safety isolation barriers, industrial robot automation control, chemical and nuclear power equipment.

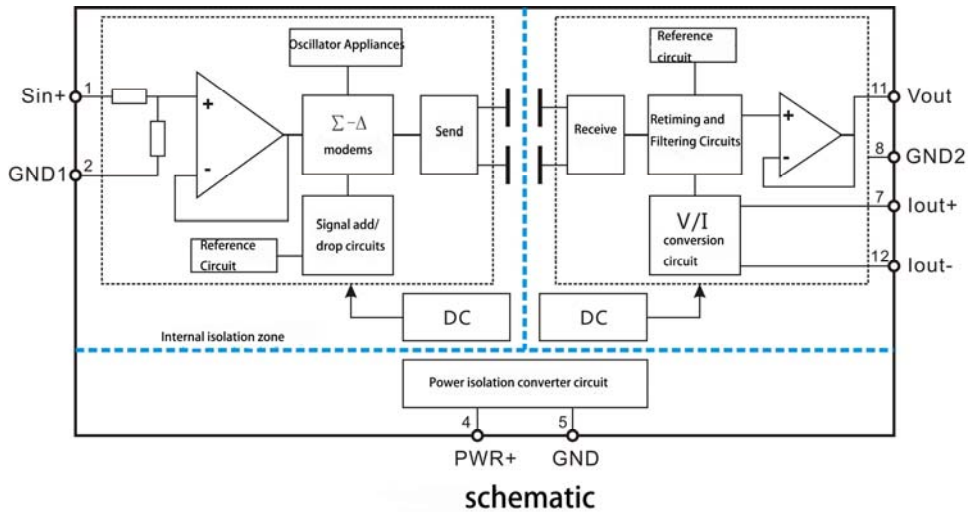

Maximum rating (Prolonged operation at maximum ratings affects product life, beyond which irreparable damage occurs.)

Continuous Isolation Voltage (Maximum continuous isolation voltage for inputs and outputs)	3KVDC/rms
PWR (Maximum input range of auxiliary supply voltage)	±25%/Vdd
Junction Temperature (Maximum range of operating ambient temperature)	-40°C ~ +85°C
Lead Temperature (Maximum pin soldering temperature and duration<10S)	+300°C
Output Voltage Load Min (Minimum load at output voltage signal)	1KΩ

Common parameter

Accuracy, Linearity Error Grade-----0.01 , 0.1 , 0.2grade	Return differential ----- < 0.05%
Auxiliary power----- 5V,12V,15V,24V DC single power supply	Isolation ----- Signal input/output/auxiliary power triple isolation
operating temperature----- -40 ~ +85°C	Electrical insulat ----- ≥200MΩ
Operating humidity----- 10 ~ 90% (condensationless)	Pressure resistance ----- 3KVDC(60HZ/S)leakage current 1mA
Storage temperature----- -55~ +105°C	Impulse voltage----- 3KVDC, 1.2/50us(peak value)
Storage humidity----- 10 ~ 95% (condensationless)	

Technical Parameters

Parameter name	Test condition	Minimal	Typical value	Maximum	Unit
Isolated Voltage	AC,50Hz,1min		3000		VDC
Isolation Impedance			10 ¹⁰ 1		Ω pF
Nominal Gain	VO=±10V		1		V/V
gain error	VO=±10V		±0.01	±0.2	%FSR
temperature drift of gain			30		ppm/°C
nonlinearity			0.1	0.2	%FSR
signal input	volts	-12.5		12.5	V
	current	-24		24	mA
Input Offset Voltage			2	5	mV
Input Impedance	volts	Vin=±10V	240		KΩ
	current	Iin=±10V	62		Ω
signal output	volts	-12.5		12.5	V

	current		-24		24	mA
load capacity	volts	Vout=±10V		2		kΩ
	current	Iout=±20mA	0	350	650	Ω
Small signal bandwidth		-3dB		10	50	KHz
capacitive load				0.1		uF
conversion rate				2		V/us
Signal output ripple		no filtering		10	20	mVRMS
Common mode rejection ratio				100		dB
auxiliary power	volts	User-defined	3.3	12	24	VDC
	power wastage			0.5	1	W
Working environment temperature			-40		85	°C
storage temperature			-55		105	°C

Note: Users who have special requirements for the product's voltage signal and current signal loading capacity should make a separate note when placing an order.

Product Model and Selection Definition (ISO EC: Capacitive isolation, ISO EM: Magnetic isolation, ISO: photo-electric isolation type products)

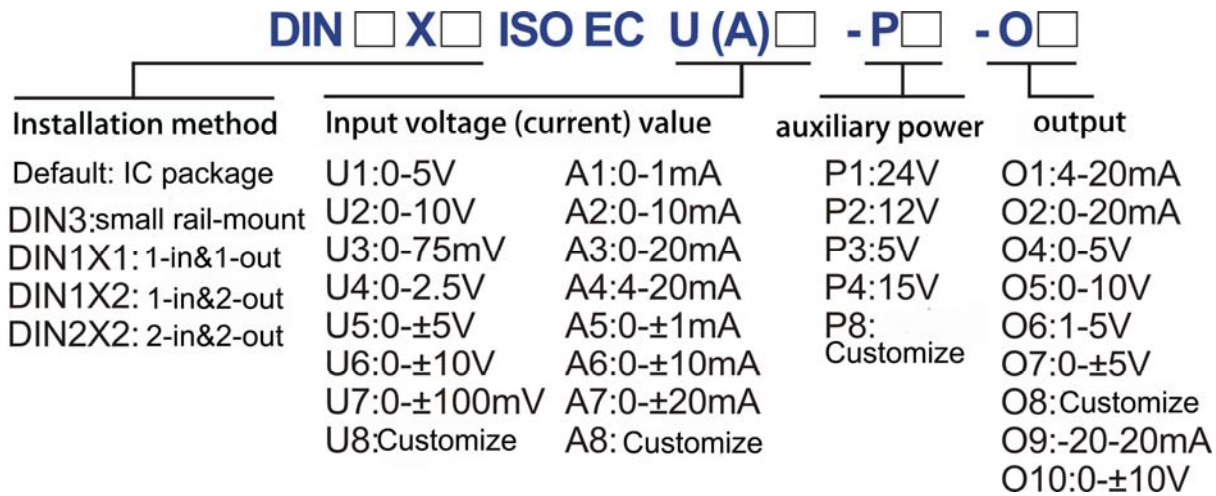

Model Selection:

For Example 1: Signal Input: 0-5V; Signal Output: 0-5V; Auxiliary Power Supply: 24VDC; Modular PCB board solder IC package.

Model No.: ISO EC U1-P1-O4

For Example 2: Signal Input: 0-10V; Signal Output: 0-20mA; Auxiliary Power Supply: 12VDC; DIN3 small volume DIN rail mounting.

Model No.: DIN3 ISO EC U2-P2-O2

For Example 3: Signal input: 0-10V; Signal output: 4-20mA; Auxiliary power supply: 24VDC; One in one out DIN35 DIN rail mounting.

Model No.: DIN 1X1 ISO EC U2-P1-O1

Shapes and PCB layout reference dimension drawing (standard SIP 12 pins)

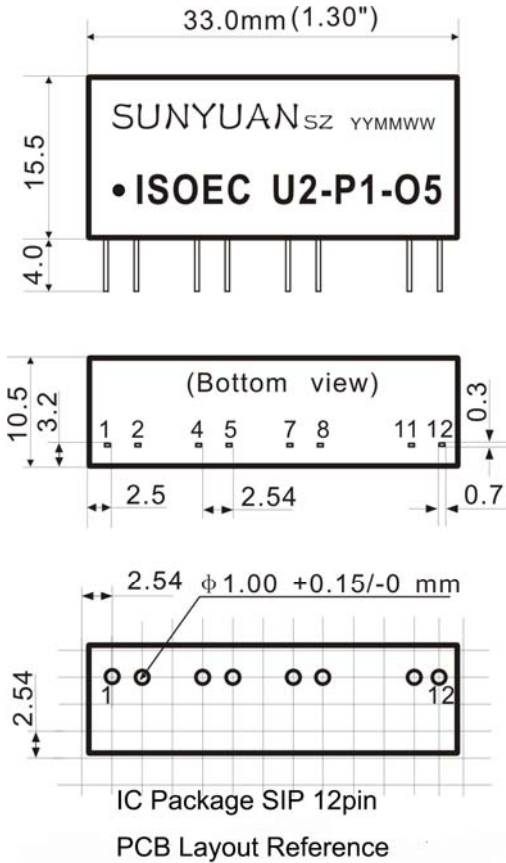

Pin Function Description

Voltage Output Type Pin Description

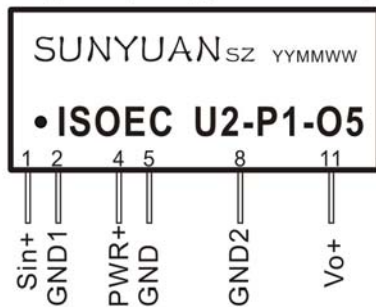

Current Output Type Pin Description

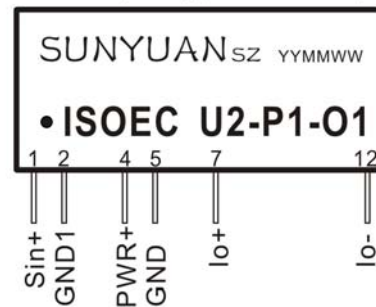

Product Pin Function Description

1	2	3	4	5	6	7	8	9~10	11	12
Sin+	GND1	NC	PWR+	GND	NC	Io+	GND2	NC	Vo+	Io-
Signal Input Positive	Signal input ground	empty	Power Input Positive	Power input ground	empty	Current Output Positive	Voltage output ground	empty	Voltage Output Positive	Current Output Negative

Typical Application Diagram of IC Packaging Products

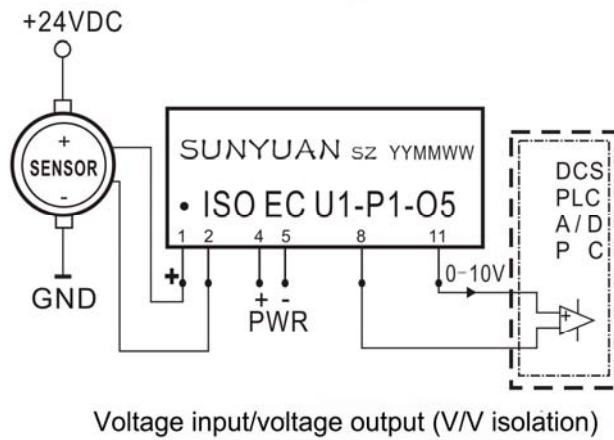
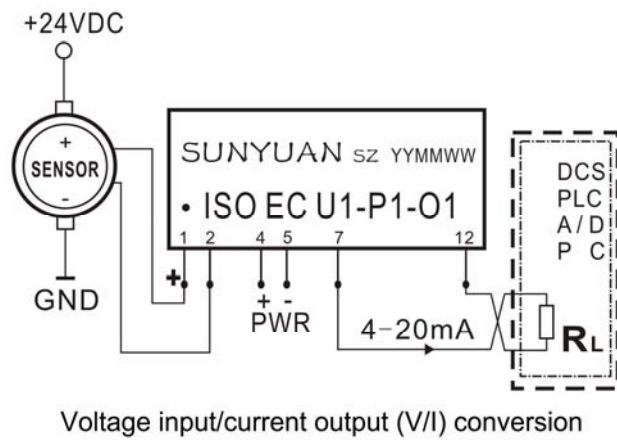
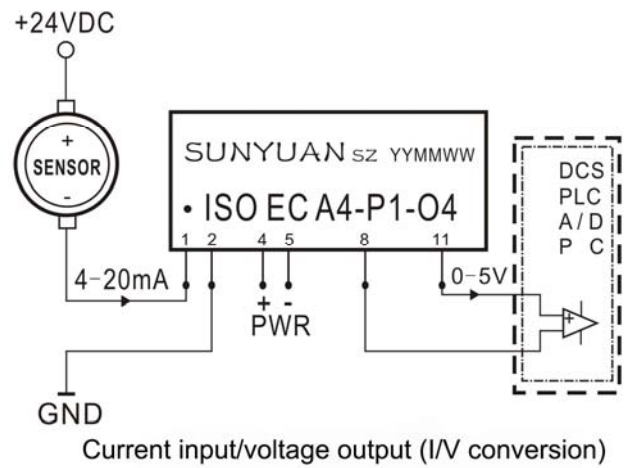
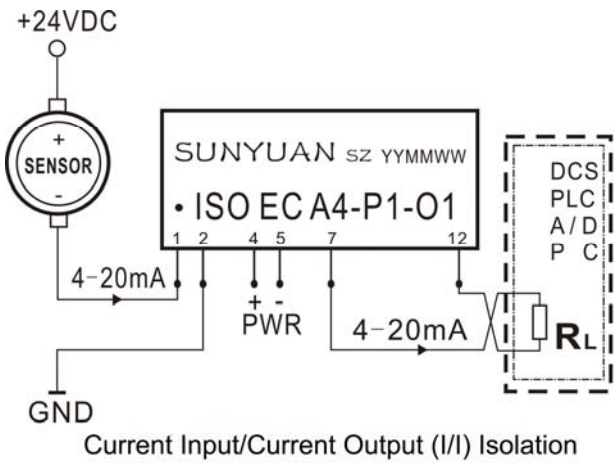

Typical Application Wiring Diagram for DIN3 Type 1-inpu&1-output DIN Rail Mounting with Small Size and Low Cost

ISO EC series analog signal isolators, isolation amplifiers, isolation transmitters can also be made into a single standard DIN 3 rail mounting. These rail-mounted analog signal isolators, isolation amplifiers, and isolation transmitters are equipped with an ISO EC series module for direct field wiring. Because of the small size and low cost characteristics of this product, the product in the power input, signal input, signal output is not installed over-voltage, over-current, reverse connection and other protection circuits, the user should be used in accordance with the characteristics of the site environment to choose to install protection devices.

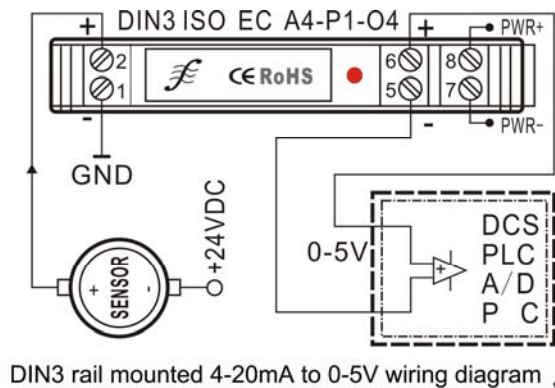
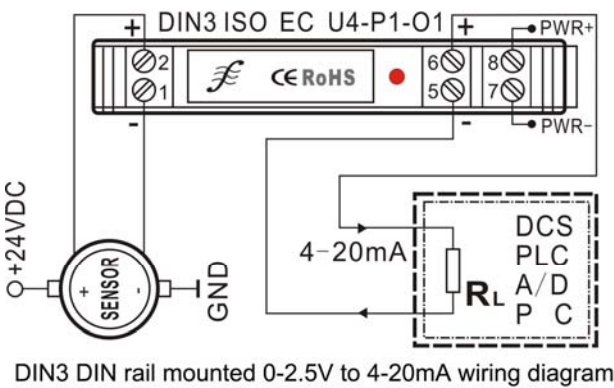

External Dimensions of DIN3 1-input&1-output rail-mounted

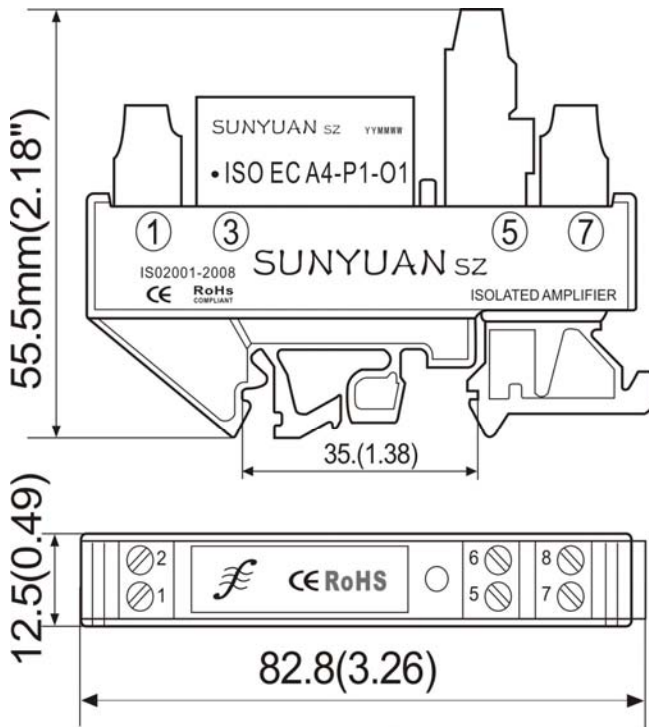

DIN3 Series Small Size Single Analog Isolation Amplifier Isolation Transmitter

Typical applications for DIN35 rail-mounted single/multiple signal isolation transmitters

The ISO EC series of analog signal isolators, isolation amplifiers and isolation transmitters can also be made into single or multi-circuit standard DIN 35 rail mounting. These rail-mounted analog signal isolators, isolation amplifiers, isolation transmitters are embedded with single or multiple ISO EC series modules, and over-voltage, over-current, reverse connection and other protection circuits have been added to the power input, signal input and signal output, which is convenient for users to use on-site direct wiring to meet the user's analog signals on-site DIN 1X1 (one in and one out), DIN 1X2 (one in and two out), DIN 2X2 (two in and two out), and other types of instruments and sensors, controllers, and other types of single-channel analog signals isolation and amplification, as well as the conversion function.

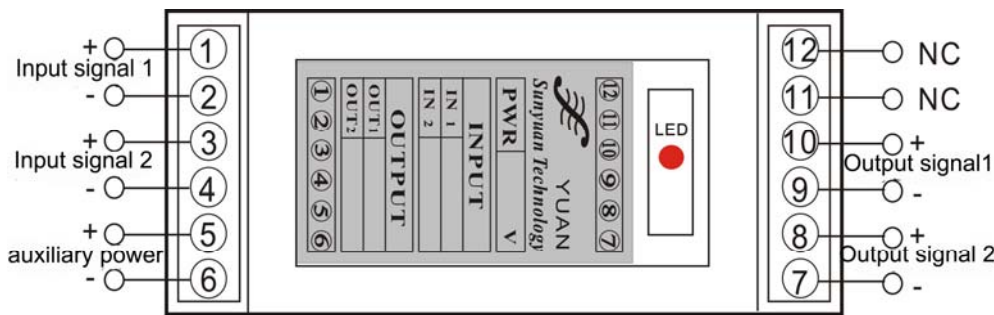

DIN1X1/1X2/2X2 Single/Multiple Isolation Amplifier Pin Function and Wiring Diagram



Pin	Pin Function	
1	Signal in1 +	Input signal 1 positive
2	Signal in1 -	Input signal 1 negative
3	Signal in2 +	Input signal 2 positive
4	Signal in2 -	Input signal 2 negative
5	Power in	Auxiliary power supply positive
6	Power GND	Auxiliary Power Supply Negative
7	Out2 -	Output signal 2 negative
8	Out2+	Output signal 2 positive
9	Out1 -	Output signal 1 negative
10	Out1+	Output signal 1 positive
11	NC	Empty
12	NC	Empty

