

DIN Rail-Mounted Frequency Transmitter
DIN1x1 ISO F-P-O

General characteristics:

- Accuracy Grade:0.1/0.2/0.5. Extremely high linearity in whole process(nonlinearity<0.1%)
 - Three-port isolation:2500VDC power supply/input/output
 - Power supply:5VDC/12VDC/24VDC etc.
 - Input frequency signal:0-1KHz/0-5KHz/0-10KHz,etc.
- Output voltage: 0-2.5V/0-5V/0-10V or current signal: 0-10mA/0-20mA/4-20mA
- Industrial temperature range: -20~+85 °C
 - DIN35 Rail Mounting package

ISO9001:2008



Applications:

- Sine wave, square wave, sawtooth wave etc. signal isolated amplifier and converter.
- Transducer(FA) frequency signal data acquisition.
- Generator, electromotor etc. Circumgyratory systems.
- Equipment and sensor signal acquisition.
- Non-electricity meter signal transfer

Part number and description:

DIN1x1 ISO- F□- P□- U(A)□

Input signal	Accessorial power supply	Output rated voltage (or current)
F1:0-1KHz	P1:DC24V	O1:4-20mA
F2:0-5KHz	P2:DC12V	O2:0-20mA
F3:0-10KHz	P3:DC5V	O4:0-5V
F8:User-defined	P4:DC15V	O5:0-10V
	P8:User-defined	O6:1-5V
		O8: User-defined

Model Selection Examples: Input: 0-1K Power Supply:24VDC ,Output:0-5V Part No.:DIN1x1 ISO F1-P1-O4

Technical parameter:

Parameter	Test Condition	Mix	Type	Max	Unit	
Isolated voltage	AC,50Hz,1min	1000	2500		V(rms)	
Input signal	Frequency	0	1000	20000	Hz	
	Voltage	2.5	5		Vp-p	
G.Adj	Voltage	5K	1		KHZ/V	
	Current	5K	1/4		KHZ/mA	
G.Adj temperature drift			100		ppm/°C	
Non-linearity			0.1		%FSR	
Input maladjusted voltage			5	7	mV	
Output signal			5	10	V	
Load capability	Vout=10V	1			kΩ	
Signal output ripple	No-filter		5	7	mV	
Signal voltage temperature drift			25		μV/°C	
Reference voltage source	Iout<50mA		5		V	
Assistant power	Voltage	User-defined	3.3	12	24	VDC
	Current	VD=24V		50		mA
Power output ripple	No-filter	10			mV	
Operating temperature		-20		80	°C	
Storage temperature		-40		125	°C	

Functional Block

DIN Rail PCB Size:79.5x32.5mm

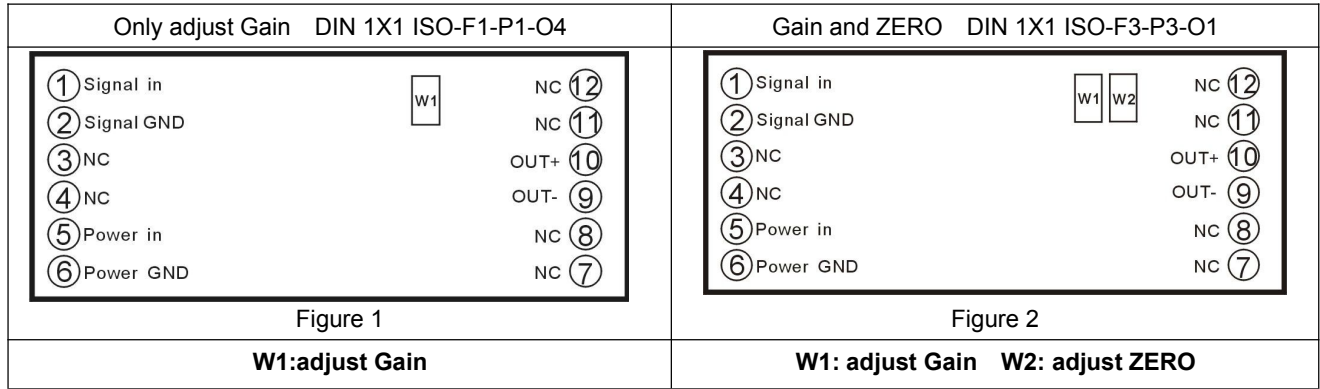

Terminal Definition:

Pin	Function
1	Fin
2	GND
3	NO PIN
4	NO PIN
5	Power in
6	Power GND
7	NO PIN
8	NO PIN
9	Out-
10	Out+
11	NO PIN
12	NO PIN

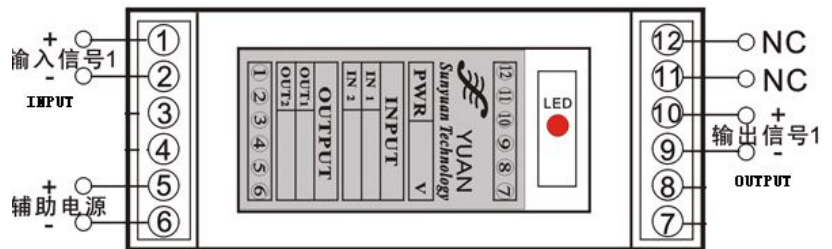

Top view

Dimension:

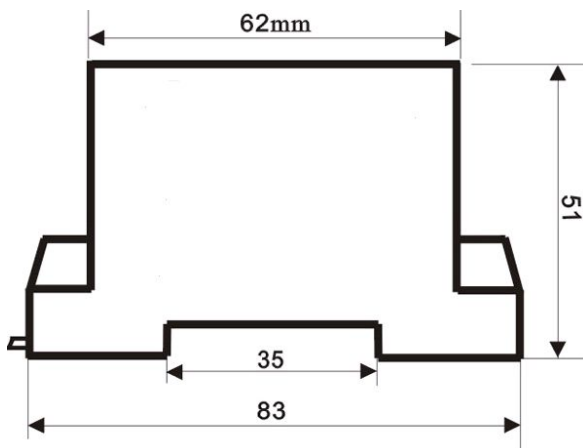

Side view



Bottom view

Note: The specification is subject to change without notice.

Frequency Signal (FV/ FI conversion) Isolation Converter IC

Sine wave, square wave, saw wave and other pulse frequency signals conversion to analog signal

ISO F-P-O Series

Features	Applications
<ul style="list-style-type: none"> • Precision grade: 0.1 0.2 0.5. • High linearity in full scale (non-linearity <0.1%) • 3kVDC isolation voltage among auxiliary power/signal input/signal output • Auxiliary power: 5VDC, 12VDC, 24VDC. • Converts 0-1KHz/0-5KHz/0-10KHz and other frequency signals into standard 0-75mV/0-2.5V/0-5V/0-10V voltage signal or 0-10mA/0-20mA/4-20mA current signal. • Small size SIP-16Pin, in accordance with UL94V-0. • Industrial operating temperature: -40~+85 °C 	<ul style="list-style-type: none"> • Sine wave, square wave, saw wave signal isolated conversion and amplification. • Frequency sensor signal acquisition, isolated conversion. • Frequency transducer(FA) frequency signal data acquisition and controlling. • Generator, electric motor and other rotating equipment speed monitoring. • Transformer operating frequency detection. • Meters, instruments and sensor signal collection and transmission. • Non-electric signal transmission.

Introduction

SUNYUAN ISO Series frequency signal isolated converter is a kind of hybrid integrated circuit IC which converts sine wave, square wave, saw wave frequency signals into standard signal based on rated proportion. Inside the circuit, it has integrated one set of multi-channel high isolation DC/DC module and a pieces of high deficient frequency signal isolation converter. The isolated converter can be applied in various types of frequency signal isolation and conversion. The SMD technique and new high-tech structures used make the 3kVDC isolation among auxiliary power, I/O and can meet the requirements in industrial operating temperature range, humidity, vibration and other extreme conditions. ISO series frequency signal isolated converter is easy to achieve the frequency signal transmission only with few external components.

Max. Rated Value: (If exceed this range, may cause un-repairable defects.)

Continuous Isolation Voltage	3KVDC/rms
PW input range	±25%Vdd
Junction (ambient)Temperature	- 45°C ~ + 85°C
Lead Temperature (<10s)	+300°C
Output Voltage Min. Load	2KΩ

Model Selection

ISO F□-P□-O□		
Input Frequency	Auxiliary Power	Output
F1: 0-1KHZ	P1: 24VDC	O1: 4-20mA
F2: 0-5KHZ	P2: 12VDC	O2: 0-20mA
F3: 0-10KHZ	P3: 5VDC	O4: 0-5V
F8: Customized	P4: 15VDC	O5: 0-10V
	P8: Customized	O6: 1-5V
		O8: Customized

Model Selection Examples

E.g.1: Signal Input: 0-1KHZ, Signal Output: 4-20 mA; Auxiliary Power: 24V, SIP 16 Package.
Product Model No: ISO F1-P1-O1

E.g.2: Signal Input: 0-10KHZ, Signal Output: 0-5V; Auxiliary Power: 12V, SIP 16 Package.
Product Model No: ISO F3-P2-O4

Technical Parameters

Items		Testing Conditions		Min.	Typical Value	Max.	Unit
Isolated Voltage		AC,50Hz,1min		1000	1500		V(rms)
Signal Input	Frequen			0	1000	20000	Hz
	Voltage			2.5	5	50	V _{P-P}
Gain	Voltage	50k	potentiometer		1		KHZ/V
	Current	50k	potentiometer		1/4		KHZ/mA
Gain Temp. Drift					100		ppm/°C
Non-linearity					0.1		%FSR
Input Offset Voltage					1	5	mV
Signal Output					5	10	V
Load capacity		Vout=10V		1	2		kΩ
Signal Output Ripple		Without filtering			5	7	mV
Signal Volt. Temp. Drift					25		μV/°C
Referential	Volt.	Output current <50mA			5		V
Auxiliary Power	Voltage	User defined		3.3	12	24	VDC
	Current	VD=24V			30		mA
Power Output Ripple		Without filtering		10			mV
Operating/Ambient				-20		85	°C
Storage Temp.				-40		125	°C

Dimension and Pin Definition

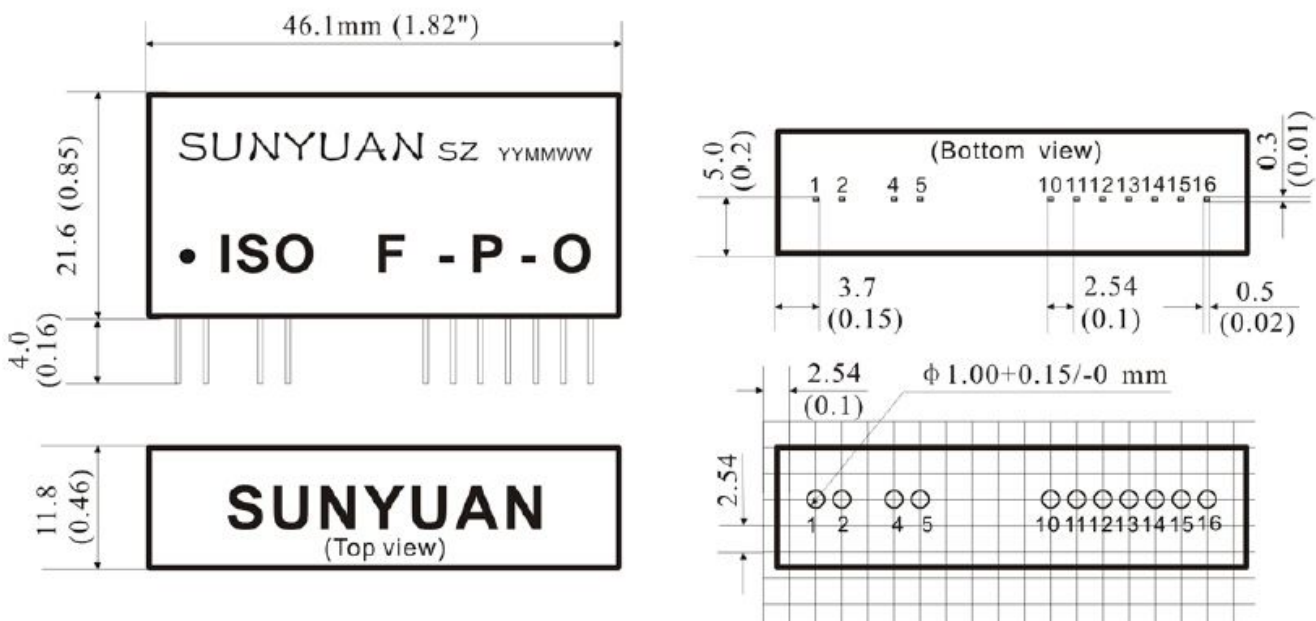

Typical Applications:

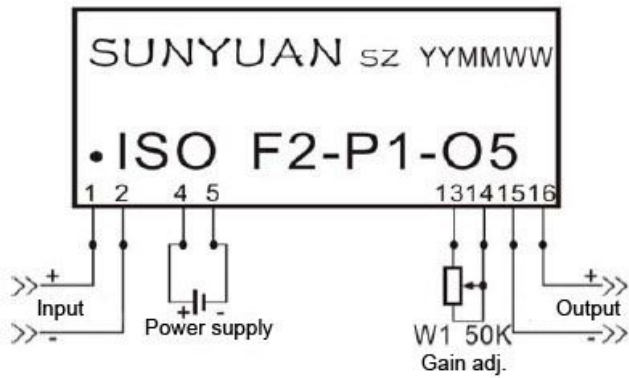

频率输入电压输出 (FV) 应用接线图

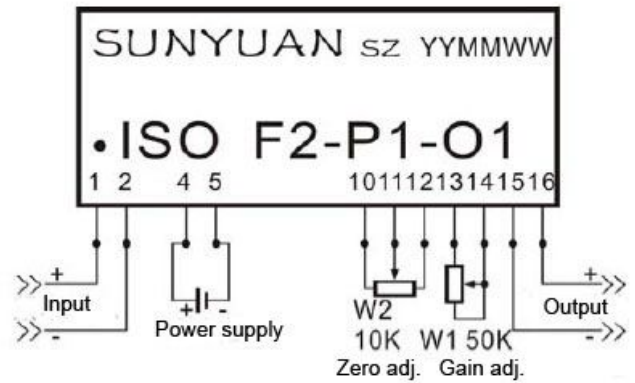

频率输入电流输出 (FI) 应用接线图

Frequency Signal to Voltage Type Pin Definition

Signal Input +	Signal Input GND	NC	Input Auxiliary Power +	Input Auxiliary Power -	NC	Gain Adj. Terminal #1 50K	Gain Adj. Terminal #2 50K	Isolated Signal Output -	Isolated Signal Output +
IN+	GND1	NC	VD+	VD-	NC	ADJ	ADJ	GND2	Vout+
1	2	3	4	5	6~12	13	14	15	16

Frequency Signal to Current Type Pin Definition

Signal Input +	Signal Input GND	NC	Auxiliary Power +	Auxiliary Power -	NC	Zero Adj. pin #1 10K	Zero Adj. pin #2 10K	Zero Adj. pin# 3 10K	Gain Adj. pin# 1 50K	Gain Adj. pin# 2 50K	Isolated Signal Output -	Isolated Signal Output +
IN+	GND1	NC	VD+	VD-	NC	ZA1	ZA2	ZA3	ADJ	ADJ	lout-	lout+
1	2	3	4	5	6~9	10	11	12	13	14	15	16

Product Show

ISO9001:2008



*Note: the specification is subject to change without notice.

Application Examples:

E.g.1 (Refer to Fig.1):

Measuring low voltage frequency signal, output voltage signal value.

Input 0-10Khz/3-10VAC frequency signal; 0-5VDC isolated output. Zero adjustment already done before ex-factory, no need to be set again. W1=50K (multi-turn potentiometer), adjust the multi-turn potentiometer to make the module output 5VDC.

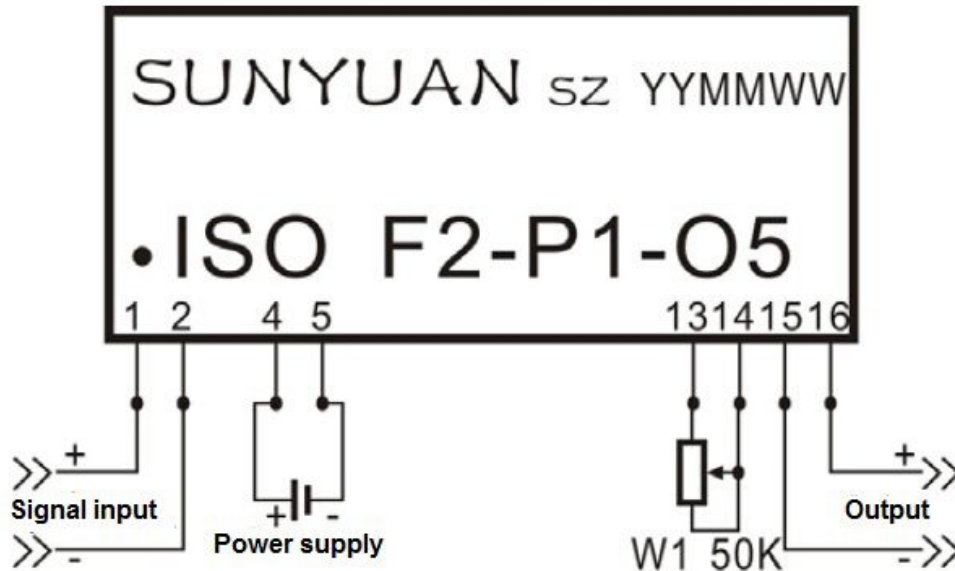

Fig. 1 Measuring low voltage frequency signal, voltage signal output

E.g.2(Refer to Fig.2):

Measuring low voltage frequency signal, output current signal value.

Input 0-10Khz/3-10VAC frequency signal; 4-20mADC isolated output. Short-circuit the input terminal, adjust W2=10K (multi-turn potentiometer) to make the module output 4mADC. Use W1=50K (multi-turn potentiometer), adjust the multi-turn potentiometer to make the module output 20mADC.

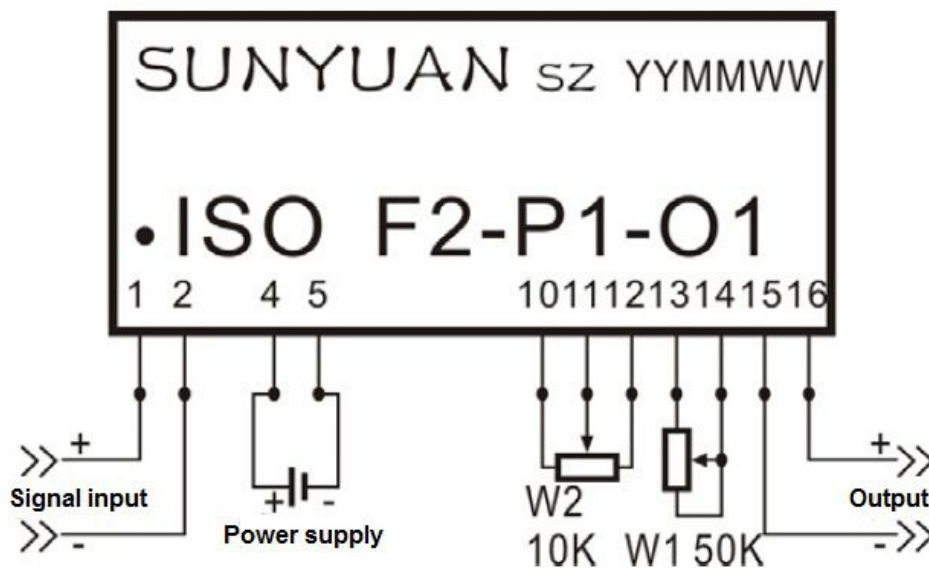

Fig. 2 Measuring low voltage frequency signal, current signal output

E.g.3(Refer to Fig.3):

Measuring high voltage frequency signal, output current signal value.

Input 0-10Khz frequency signal, frequency amplitude is higher than 10V; 4-20mADC isolated output. Short-circuit the input terminal, adjust W2=10K (multi-turn potentiometer) to make the module output 4mADC. Use W1=50K (multi-turn potentiometer), adjust the multi-turn potentiometer to make the module output 20mADC.

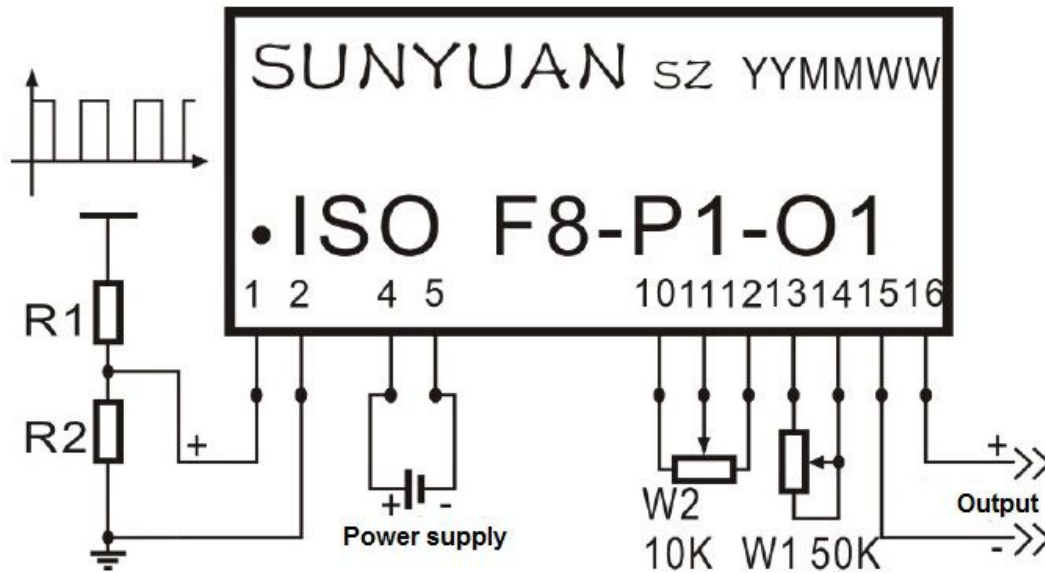

Fig. 3 Measuring high voltage frequency signal, current signal output