

ISO SY AD 02C Series Analog signal isolated acquisition A/D Converter with Temperature Detection

Product Introduction

Features:

- Low cost, small size
- Analog signal acquisition, isolated conversion RS-485/232 output
- Analog signal output accuracy>0.05%
- RS-485/232 output, can be remotely reconfigured for modules accuracy
- Input signal/Output signal 3000VDC
- Wide power supply range : 8 ~ 50VDC
- High reliability, convenient programming, easy installation and wiring
- User can set module address and baud rate, etc. by programming
- Support Modbus RTU communication protocol
- Support one channel DS18B20 temperature signal input, with resolution of 0.01 °C.

Applications:

- Signal testing/ monitoring /control
- Intelligent building control, security and engineering applications
- RS-232/485 industrial automation control system
- Industrial fields signal isolation and long-terms transmission
- Debugging and controlling of equipment operation
- Sensors signal test
- Acquisition and record of industrial field data
- Development of medical and industrial products
- -55~125°C temperature measure

Product Overview:

Sunyuan SY AD series achieve the signal acquisition between sensor and the host to test analog signal or control remote device. The configuration software can be used for a variety of sensors including analog input, analog output, and digital signal input / output (I / O), ISO 4021 series of products can be used in industrial automation RS-232/485 bus system, 4-20mA / 0-10V signal measurement, monitoring and control, small-signal measurement, and industrial-site signal isolation and long-term transmission and so on.

Products include power supply isolation, signal isolation, linearization, A/D conversion and RS-485 serial communication. Each serial port of the maximum 256 ISO 4021 series of modules, means of communication using ASCII character communication protocol or MODBUS RTU communication protocol communication protocol, its instruction set compatible with the ADAM modules, the baud rate is set by the user, with other manufacturers control module hanging in the same RS-485 bus, to facilitate computer programming.

SYAD series of products are based on single chip of intelligent monitoring and control systems, all the user to set the calibration value, address, baud rate, data format, checksum status and other configuration information is stored in nonvolatile memory EEPROM inside.

SYAD series of products according to industry standard design, manufacture, signal output / communication interface isolation, can withstand 3000VDC isolation voltage, anti-interference ability, high reliability. Operating temperature range: - 45°C ~ +80°C.

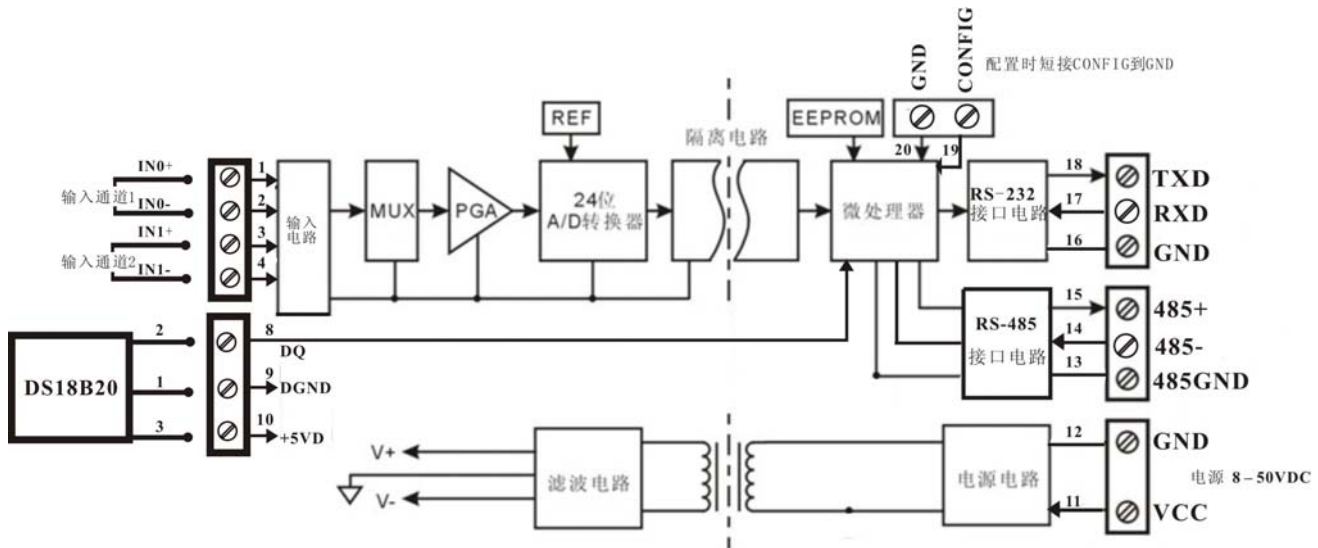

Figure 1 SY AD 02C functional block diagram

Function of SY AD 02C:

SY AD 02C signal isolation acquisition module could be used to test one channel voltage/current; it could also be used to test 2-channel current/voltage signal which are common grounded and isolated.

Analog signal input

24-bit output accuracy. The product has been calibrated before delivery. It is also convenient to be programmed and calibrated by the user during the usage.

The specific current or voltage output range need to be corresponding to the selection of product. The two outputs selection should be the same when outputting two signals.

Communication protocol

Communication Interface: 1 standard RS-485 interface or 1 standard RS-232 interface. Please note before ordering.

Communication protocol: support two types of protocols, one is standard Modbus RTU communication protocol and the other is character communication protocol. User could decide which protocol to use by programming. The product could have network communication with supervisory computer control system or various types of brands such as PLC, RTU.

Data format: 10 bit. One start bit, 8 data bit, one stop bit.

Communication address (00H~FFH) and baud rate (300、600、1200、2400、4800、9600、19200、38400bps) could be set; The network communication distance is up to 1200 meters, connecting by double ground shield cable.

High anti-jamming of the communication interface, ±15KV ESD protection, and the response time is less than 100mS.

Anti-jamming

Set checksum according to requirements. TVS inside the module can actively restrain all kinds of surge impulse and protect the module. Digital filter inside could also restrain the power frequency jamming from power grid.

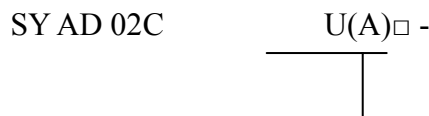
Model selection:

Input voltage or current signal

U1: 0-5V	A1: 0-1mA
U2: 0-10V	A2: 0-10mA
U3: 0-75mV	A3: 0-20mA
U4: 0-2.5V	A4: 4-20mA
U5: 0-±5V	A5: 0-±1mA
U6: 0-±10V	A6: 0-±10mA
U7: 0-±100mV	A7: 0-±20mA
U8: Customized	A8: Customized

Note: SY AD 02C can support RS232 and RS485 communication port, user can choose the communication port according the application environment. But at the same time, only one communication port can work, or will have interference.

E.g.:

- 1, SY AD 02C A4 Means 4-20ma signal output, and support one channel DS18B20 temperature signal input
- 2, SY AD 02C A7 Means 0-5V signal output, and support one channel DS18B20 temperature signal input
- 3, SY AD 02C U1 Means 0-±5V signal output, and support one channel DS18B20 temperature signal input

SY AD 02C general parameters:

(typical @ +25°C, Vs@24VDC)

Input: Voltage / Current

Accuracy: 0.05%

put imbalanceIn: ±0.1 uA/°C

Temperature Drift: ±15 ppm/°C (±30 ppm/°C, max)

Input load: 50Ω (4-20mA/0-20mA/0-±20mA current input)

100Ω (0-10mA/0-±10mA current input)

1KΩ (0-1mA/0-±1mA current input)

>1MΩ(voltage input)

Band width: -3 dB 10 Hz

Switching rate: 10 Sps

Common mode restraint(CMR): 120 dB (1kΩ Source Imbalance @ 50/60 Hz)

Normal mode restraint(NMR): 60 dB (1kΩ Source Imbalance @ 50/60 Hz)

Temperature Measure Range: -55°C~+125°C, with inherent temperature resolution 0.5°C.

Input terminal protection: over-voltage/over current protection

Communications: protocol RS-485 or RS-232 ASCII character communication protocol and MODBUS RTU communication protocol

Baud rate (300、600、1200、2400、4800、9600、19200、38400bps) software selectable

address (00H~FFH) software selectable

Response Time: 100 ms max

Operation Power Supply: +8 ~ 50 VDC wide power supply range, internal anti-reverse & over-voltage protection

watt consumption: < 1W

Operation Temperature: - 45 ~ +80°C

Operation Humidity: 10 ~ 90% (non-condensing)

Storage Temperature: - 45 ~ +80°C

Storage Humidity: 10 ~ 95% (non-condensing)

Isolation withstand voltage: between input and output: 3KVDC, 1 minute, stray current 1mA
Output and power are common-ground.

Endure Impact Voltage: 3KVAC, 1.2/50us(peak value)

Dimensions: 120 mm x 70 mm x 30mm

Weight: approximately 72g

Pin description:

Pin	Name	Description
1	IN0+	Input0 +
2	IN0-	Input0 -
3	IN1+	Input1 +
4	IN1-	Input1 -
5	+5VA	+5V Analog Power supply +
6	AGND	Analog Ground
7	NC	NC
8	DQ	DS18B20 input
9	DGND	Digital Ground
10	+5VD	+5V digital output
11	VCC	Power supply +
12	GND	Power supply -
13	485GND	485GND
14	485-	RS-485- Ground
15	485+	RS-485+ Ground
16	GND	232GND
17	RXD	RS232RXD
18	TXD	RS232TXD
19	CONFIG	Config initiation
20	GND	GND

Table1 Pin description



Figure 2 Figure of SY AD 02C

Wiring Diagram:

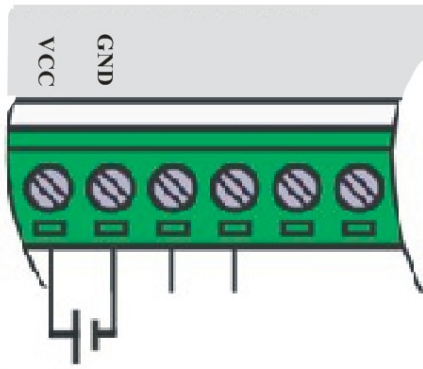

电源：8-50VDC

Figure 3 power supply wiring scheme

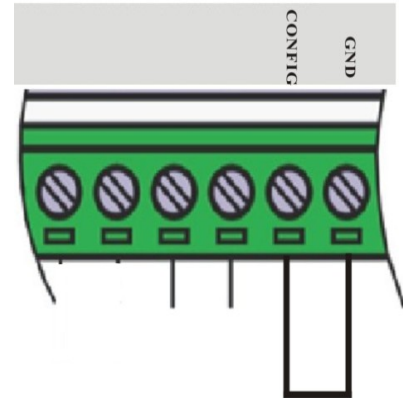

先短接CONFIG到GND, 再上电开机。则模块进入配置模式

Figure 4 Configuration wiring

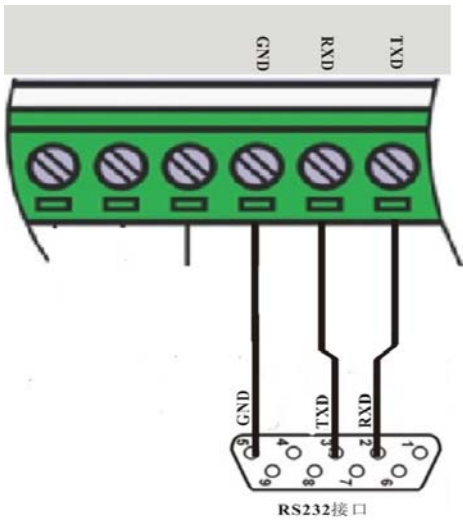

Figure 5 RS232 interface wiring

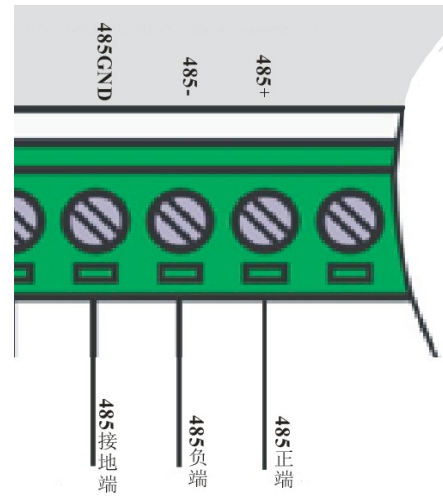

Figure 6 RS485 interface wiring

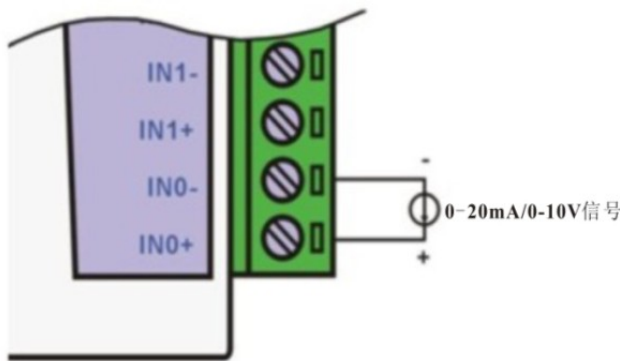

Figure6 input signal wiring

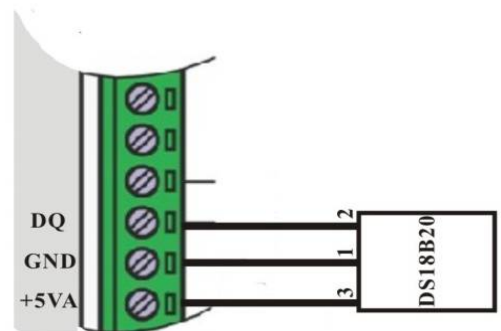

Figure8 Input temperature signal wiring

Initialization of SY AD 02C Module:

Access RS-232 / RS-485 network, for SY AD 02C module must be assigned a unique address code, address the code of address should be hexadecimal number, value between 0 x00 and 0 x FF. All new ISO4021C modules USE the same factory initial set. See below:

Address code of 01H
baud rate is 9600 bps
Checksum prohibited

Communication protocol is character communication protocol

As the new module code is the same, their address will be contradictory with other modules, so when you set up the system, you must re-configure each analog output module address. Users can modify ISO SY AD 02C module's address through configuration commands after connecting ISODA module power cable and RS485 communication lines. Baud rate, parity, status, and communication protocols can also be adjusted according to user's requirements. Before the adjusting process, one must set the module to the default state firstly; otherwise it can not be modified.

Let the modules be in default status:

SY AD 02C module has a Pin marked CONFIG. Connect CONFIG Pin to the ground (GND) as Figure 4, and then connect power supply. In this way, the module is in default status.

Under default status, the module setting is as following:

Address code: 00H

Baud rate: 9600 bps

Checksum: disable

ASCII Character communication protocol

At this time, users can modify SY AD 02C module, baud rate, checksum state and other parameters by configuring the command and select the means of communication by setting the module's communication protocol command. If the configuration of a module is uncertain, the module could be in default state by installing the jumper and then reconfigure the module.

If user needs the module to be set to MODBUS RTU communication protocol, see introduction of MODBUS communication protocol section for information.

Module Calibration:

Calibration must be conducted under ASCII communication protocol, Modbus communication do not support calibration.

Product has been calibrated ex-factory, user can directly use and do not need calibration. In using, user can re-calibrate the module. It need accurate signal when calibrating, different input rang need different input signal.

To improve the calibration accuracy, we suggest using below equipment for calibration:

One regulation output, low-noise DC current/voltage signal source

One 5 and half bit or higher precision voltage /current instruments for dictation the accuracy of the input signal.

Calibration order:

1. Choose the input channel that need to be calibrated, connect accordingly input signal regard to the input range.
2. When calibrate "Zero", the input should be "0", when adjust span, the input should be span's 120%, such as, 4-20mA input, when adjust Zero, the input should be 0mA, when adjust 20mA, the input should be 24mA.
3. The zero signal of analog input module usually be 0mA or 0V.
4. After the signal is stable, send command to the module: offset calibration \$AA1N(N represents the calibrating channel, 0 or 1)
5. Input 120% current or voltage signal of module's span to the calibrating channel.
6. after signal is stable, send command to the module: Gain calibration \$AAON(N represents the calibrating channel, 0 or 1)
7. Calibration finished.

The specification of DS18B20 temperature value processing instructions:

SY AD 02C support a single DS18B20 temperature measurement, the DS18B20 temperature signal from the input SY AD 02C 8-pin (DQ), 9 feet (DGND digital power supply negative terminal) and the 10 feet (5VD digital power supply positive terminal) can DS18B20 external 5V power supply. SY AD 02C only support the the DS18B20 auxiliary power supply work, does not support the parasitic power work. The measurement signal processing by the microprocessor through the serial port can be uploaded to the host communication supports two modes, ASCII and MODBUS RTU mode.

ASCII mode

this mode, the SY AD 02C module after receives the data read command (# AA or #AA2, where AA represents the address, channel 3), the data was uploaded to the host. Command # AA is to read the data of all channels, SY AD 02C has three analog signal path, the temperature value is on the third channel. If only to read the temperature value, enter the command # AA2 can make it. (Need to open the third channel; the channel status is set to: 0000 01XX). The data format is: the sign bit (+/-) and data bits, data bits by the three integers and two decimal places. Such as +023.75 represents 23.75 ° C. If the DS18B20 is not working properly (missed or damage), the module will send the message: C18B20: Prompts the user to check the sensor. In this mode, data can also be transmitted to four hexadecimal data in form to the host, high in the former, including the sign bit and data bits. Convert decimal data; please refer to the DS18B20 data sheet.

Note: The temperature data format does not support a percentage format.

MODBUS RTU mode

This mode, the SY AD 02C module receives a data read command (03H), temperature and analog data acquisition value with the upload to the host, the data for four hexadecimal number, the previous high, the data register address 0003H. Contains the sign bit and data bits, and For DS18B20 collected temperature value is converted to the corresponding decimal value, please refer to the DS18B20 data sheet. In this mode, if the DS18B20 missed or damaged, the module will send a fixed value of 0025H.

ASCII Character Communication Protocol**Brief introduction:**

When the controller communicates on the Modbus under ASCII character protocol mode, every 8-bit of a message is transmitted as two ASCII bytes. E.g. Transmit the number 34: it transmits 0x33 (ASCII code of 3) and 0x34 (ASCII code of 4) separately. The advantage is that the interval of sending the bytes is only 1s without error.

Format of each ASCII code's byte:

Coding systems: hexadecimal, ASCII characters 0-9, AF 1 16 hex

Data bits: 1 start bit

7-bit data, LSB prior delivery

Odd / even parity: 1 bit; no parity: 0 bit

When there is parity: 1 parity bit, 1 stop bit; no parity: 2 stop bits

Error checking District: Longitudinal Redundancy Check

Character protocol command set

The command consists of a series of characters, such as the leading code, address ID, variables, and optional checksum byte and a stop command (cr). ISO4021C module does not support the broadcast address, so the host only commands one ISO4021 module each time.

Command format: (Leading Code)(Addr)(Command)[data][checksum](cr)

(Leading code) It is the first letter of a command. Every command requires a leading code, such as %, \$, #, @, etc. 1- C

(Addr)Address code of a module. Its range is from 00 to FF (hexadecimal) if there is no allocation. 2- C

(Command)Display command code or variable value. Extent of variable value

[data] Some output command requires. Extent of variable value

[checksum] Checksum in the bracket displays optional parameters. It is required only when checksum is used. 2- C

(cr) a control code character which is used as the end code. It is 0x0D. 1- C

[Checksum] is needed when enabling checksum. It takes up 2 characters. Commands and responses must have checksum feature. Checksum is used to check all input commands to help user finding the command error from the host machine to the module, or response error from module to the host. Checksum character follows command or response character and in front of the carriage return.

Calculation method: Get the sum of ASCII code value of all prior issued bytes. This sum and hexadecimal digits 0xFF is two characters (the hexadecimal number).

E.g. prohibit checksum

User command \$022(cr)

Module response !02000600 (cr)

Enable checksum

User command \$022B8 (cr)

Module response !02000640AD (cr)

'\$' = 0x24 '0' = 0x30 '2' = 0x32

B8=(0x24+0x30+0x32+0x32) AND 0xFF

'!' = 0x21 '0' = 0x30 '2' = 0x32 '4' = 0x34 '6' = 0x36

AD=(0x21+0x30+0x32+0x30+0x30+0x30+0x36+0x34+0x30) AND 0xFF

Common command:

- 1、 Read analog input module data
- 2、 set the analog output value of channel N
- 3、 module allocation
- 4、 Read allocation status
- 5、 Offset calibration
- 6、 Full scale calibration
- 7、 Read module name
- 8、 Enable or prohibit channel command
- 9、 read channel status command
- 10、 Set communication mode

Response of commands:

Response message depends on a variety of commands. Response also consists of several characters, including leading code, variables and end tags. There are two leading codes of response signal: '!' or '>' indicates a valid command and '?' means invalid. By checking the response information, user can monitor whether the command is valid or not.

Note: 1, in some cases, many commands use the same command syntax. User needs to ensure the address he uses is correct in a command. If one use the wrong address and this address represents another module,

then the command will take effect in another module, resulting in an error.

2, the command must be entered in capital letters.

1、Read analog input module data

Description : Based on the current data format, the command is to read analog input value of all channels from the module. Including the value of the temperature acquisition.

Syntax : #AA(cr)

Parameter Description : # delimiter character
 AA Module address, value range 00H~FFH(hexadecimal).
 (cr) end character , carriage return (0DH)。

Response: >(data)(cr) command is valid.
 ?AA(cr) invalid command or illegal operation

Parameter Description : > delimiter character
 (data) Represent the data of all channels which been read by the command. The data format is in Engineering Units, PERCENT OF FSR, complement of hexadecimal or ohms。 Refer to Chapter 3 Command Set.

(cr) end character , carriage return (0DH)。

More instructions: If there is a syntax error or communication error or address does not exist, the module does not respond.

If a channel has been shut down, then the data read out as space character.

E.g. user command #23(cr)
 Module response >+04.765+04.756+020.05 (cr)

Description : on module of 23H, input is (data format is engineering unit):

Channel 0: +04.765mA channel 1: +04.756mA the following +020.05 shows the current temperature is +20.05°C

2、Read the data of analog input module in Channel N

Description : Read the analog input data of channel N at the current allocated data format.

Syntax : #AAN(cr)

Parameter Description : # delimiter character
 AA Module address, value range 00H~FFH。
 N channel 0 or 1
 (cr) end character , carriage return (0DH)。

Response: >(data)(cr) command is valid.
 ?AA(cr) invalid command or illegal operation or channel is closed.

Parameter Description : > delimiter character
 (data) data read in channel N. The data format is in Engineering Units, PERCENT OF FSR, complement of hexadecimal. Or ohms。 Refer to Chapter 3 Command Set.

(cr) end character , carriage return (0DH)。

More instructions: If there is a syntax error or communication error or address does not exist, the module does not respond. Only read the temperature value, users can directly send the command: #AA2 to read back the current temperature value.

E.g. user command #230(cr)
 Module response >+04.632 (cr)

Description : The input current of channel 0 on address 23H module is +04.632mA (data format is engineering unit)

3、 module allocation

Description : Set address, input range, baud rate, data format, checksum status for an analog input module. Configuration information is stored in nonvolatile memory EEPROM.

Syntax : %AANNTTCCFF(cr)

Parameter Description : % delimiter character

AA Module address, value range 00H~FFH

NN hexadecimal address, NN is from 00 to FF

TT hexadecimal represents type code. ISO4021C module should be set as 00

CC hexadecimal represents baud rate code. Refer to table 2

baud rate code	baud rate
01	300bps
02	600bps
03	1200bps
04	2400bps
05	4800bps
06	9600bps
07	19200bps
08	38400bps

Table 2 Baud rate code

FF The 8-bit of hexadecimal is used to represent data format and checksum. Note: From bits2 to bits 5 is unnecessary to be set to 0.

Bit7	Bit 6	Bit 5	Bit 4	Bit 3	Bit2	Bit 1	Bit 0
------	-------	-------	-------	-------	------	-------	-------

Table 3 data format, checksum code

Bit7: Reserved bits should be set to 0

Bit6: checksum status: 0 represents prohibit; 1 represents permission

Bit5-bit2: it's unnecessary and used to be set to 0

Bit1-bit0: data format bit

00: Engineering Units

01: % of FSR

10: complement of hexadecimal (Twos complement)

11: ohms(only the thermal resistance could be set)

(cr) end character , carriage return (0DH)。

Response: !AA(cr) command is valid.

?AA(cr) invalid command or illegal operation, no jumper allocation before baud rate checksum status.

Parameter Description : ! delimiter code indicates valid command.

? delimiter code indicates invalid command.

AA indicates input Module address

(cr) end character , carriage return (0DH)

More instructions: If need to reallocate module, user should install jumper to let the module be in default status. Now Module address is 00H, that is to say AA=00H, NN = new address. Otherwise it will respond error signal.

Once the command is executed, the new address will be set as response information and be send back to the host machine by the module after reallocation.

If there is a syntax error or communication error or address does not exist, the module does not respond.

E.g. user command %0011000600(cr)
 Module response !11(cr)

Description : % delimiter character

00 Indicate the analog module original address which user wants to allocate is 00H.

11 Indicate the hexadecimal address of the new address is 11H.

00 type code, ISO4021C series should be set to 00.

06 Indicate baud rate 9600bps

00 Indicate data format is engineering unit and the checksum is forbidden.

4、 read the allocation status

Description : read the allocation of the specified module

Syntax : \$AA2(cr)

Parameter Description : \$ delimiter character

AA Module address, value range 00H~FFH

2 read the allocation status

(cr) end character , carriage return (0DH)

Response: !AATCCFF(cr) command is valid.

?AA(cr) invalid command or illegal operation

Parameter Description : ! delimiter character

AA input module address。

TT Type code

CC baud rate code, table 3 for reference

FF table 4 for reference

(cr) end character, upper computer Return key (0DH)

More instructions: If there is a syntax error or communication error or address does not exist, the module does not respond.

E.g. User command \$302(cr)

Module response !300F0600(cr)

Description : ! delimiter character

30 analog input module addresses is 30H

00 input type code

06 baud rate 9600 bps。

00 data format is engineering unit and the checksum is forbidden.

5、 Offset calibration

Description : Adjust the offset of channel N

Syntax : \$AA1N(cr)

Parameter Description : \$ delimiter character

AA Module address, value range 00H~FFH

Offset calibration

N channel 0~1

(cr) end character , carriage return (0DH)。

Response: !AA(cr) command is valid.

?AA(cr) invalid command or illegal operation

Parameter Description : ! delimiter code which means valid command

? delimiter code means invalid command

AA input Module address

(cr) end character , carriage return (0DH)。

More instructions: The product has been calibrated before delivery, and the user can directly use it without calibration. When calibrating an analog input, offset calibration should be done firstly, and then calibrate the gain. During the calibration, analog input module needs to be connected with the appropriate input signal on the channel which is to be calibrated. Different input range requires different input voltage or current. See the calibration module section.

If there is a syntax error or communication error or address does not exist, the module does not respond.

E.g. user command \$2310(cr)
 Module response !23(cr)

Description : offset calibrating channel 0 of address 23H

6、Gain calibration command

Description : calibrate the gain of channel N

Syntax : \$AA0N(cr)

Parameter Description : \$delimiter character

 AA Module address, value range 00H~FFH

Gain calibration command

N channel 0~1

(cr) end character , carriage return (0DH)。

Response: !AA(cr) command is valid.

 ?AA(cr) invalid command or illegal operation

Parameter Description : ! delimiter code means valid command

 ? delimiter code means invalid command

 AA Input Module address

(cr) end character , carriage return (0DH)。

More instructions: The product has been calibrated before delivery, and the user can directly use it without calibration.

When calibrating an analog input, offset calibration should be done firstly, and then calibrate the gain.

During the calibration, analog input module needs to be connected with the appropriate input signal on the channel which as to be calibrated. Different input range requires different input voltage or current. See the calibration module section.

If there is a syntax error or communication error or address does not exist, the module does not respond.

E.g. User command \$2303(cr)
 Module response !23(cr)

Description : gain calibrating channel 0 of address 23H

7、Read module name

Description : Read module name

Syntax : \$AAM(cr)

Parameter Description : \$ delimiter character

 AA Module address, value range 00H~FFH

 M Read module name

(cr) end character , carriage return (0DH)。

Response: !AA(ModuleName)(cr) command is valid.

 ?AA(cr) invalid command or illegal operation

Parameter Description : ! delimiter character :command is valid.

? delimiter character :command is invalid.

AA input Module address.

(ModuleName) module name could be ISOADA08、ISO 4021C or ISO4014 etc. Means the module type you used.

(cr) end character , carriage return (0DH)

More instructions: If there is a syntax error or communication error or address does not exist, the module does not respond.

E.g. User command \$08M(cr)

Module response !08ISO 4021C (cr)

Description : Module ISO 4021C is in address 08H module.

8、Enable or prohibit command channel

Description : Enable or prohibit the data acquisition channel of the module

Syntax : \$AA5VV(cr)

Parameter Description : \$ delimiter character

AA Module address, value range 00H~FFH。

5 The command means enable or prohibit the data acquisition channel of the module

VV two bids (hexadecimal), 3~0 at the first bid represents 7~2 channel.

3~0 at the second bid 3~0 channel

Bit is 0: prohibit the channel

Bit is 1: enable the channel

(cr) end character , carriage return (0DH)。

Response: !AA(cr) command is valid.

?AA(cr) invalid command or illegal operation

Parameter Description : ! delimiter character :command is valid.

? delimiter character: command is invalid.

AA input Module address。

(cr) end character , carriage return (0DH)。

More instructions: If there is a syntax error or communication error or address does not exist, the module does not respond.

If you need to read the temperature, need to open the third channel (channel 2). (V = x1xx).

E.g. User command \$08501(cr)

Module response !08 (cr)

Description : set channel value to 0x01。

0 is 0000, represents prohibit channel 7, channel6, channel 5 and channel 4.

1 is 0001, represents enable channel 0, prohibit channel 3, channel 2 and channel 1.

9、Read the channel status

Description : Read the channel status

Syntax : \$AA6(cr)

Parameter Description : \$ delimiter character

AA Module address, value range 00H~FFH。

6 Read the channel status

(cr) end character , carriage return (0DH)。

Response: !AAVV(cr) command is valid.

?AA(cr) invalid command or illegal operation

Parameter Description : ! delimiter character :command is valid.

? delimiter character: command is invalid.
 AA input Module address。
 VV two bids (hexadecimal), bits 3~0 of the first number represent 7~4 channel
 Bids 3~0 of the second number represent 3~0 channel
 Bit is 0: prohibit the channel
 Bit is 1: enable the channel
 (cr) end character , carriage return (0DH)。

More instructions: If there is a syntax error or communication error or address does not exist, the module does not respond.

E.g. User command \$186 (cr)
 Module response !1803(cr)

Description : the current channel status is 0x03.

0x03 is 0000 and 0011, means all the channels of module at address 18H have been enabled.

10、Set communication protocol command

Description : Set the communication protocol of module as character communication protocol or Modbus RTU protocol.

Syntax : \$AAPV(cr)

Parameter Description : \$ delimiter character

AA Module address, value range 00H~FFH

P set communication protocol

V the code of the protocol could be 0 or 1.

0: ASCII character communication protocol

1: Modbus RTU protocol

(cr) end character , carriage return (0DH)

Response: !AA(cr) command is valid.

?AA(cr) invalid command or illegal operation

Parameter Description : ! delimiter character :command is valid.

? delimiter character: command is invalid.

AA input Module address。

(cr) end character , carriage return (0DH)。

More instructions: If there is a syntax error or communication error or address does not exist, the module does not respond.

Setting communication protocol command is only valid under default status.

e.g.1: user command \$00P1(cr)
 Module response !00 (cr)

Description : set communication protocol as Modbus RTU protocol

e.g.2: user command \$00P0(cr)
 Module response !00 (cr)

Description : Set the communication protocol of module as character communication protocol

11. Set host mode send interval command

Command functions: set host mode send interval

Command syntax: \$AATNNNN(cr)

Parameter Discription: \$ delimiter

AA target module address, value range: 00H ~ FFH

T The keyword of set the host mode sends interval command

NNNN Send intervals, can be 1-3600 seconds. If the baud rate more is 300, the interval should more than 5 seconds. If the baud rate is 500, the interval should more than 3 seconds.
 (cr) terminator, Host computer enter key (ODH)

Response syntax: !AA(cr) Command effective
 ?AA(cr) Command invalid or illegal operation

Parameter specification:
 ! delimiter the command is valid
 ? delimiter the command is invalid
 AA represents target module address
 (cr) terminator, Host computer enter key (ODH)

Other notes: if address error or communication error, the target module do not response.

Application example:

User command: \$00T0060(cr)
 Module response: !00 (cr)
 Description: set the send interval of 60 seconds

12. Read host mode sends interval command

Command functions: Read host mode send interval

Command syntax: \$AAJ(cr)

Parameter Discription: \$ delimiter
 AA target module address, value range: 00H ~ FFH
 J The keyword of read the host mode sends interval command
 (cr) terminator, Host computer enter key (ODH)

Response syntax:: !AA(NNNN)(cr) Command valid
 ?AA(cr) Command invalid or illegal operation

Parameter specification:
 ! delimiter the command is valid
 ? delimiter the command is invalid
 AA represents target module address
 (NNNN) Send intervals, can be 1-3600 seconds
 (cr) terminator, Host computer enter key (ODH)

Other notes: if syntax error or communication error or address does not exist, the target module will not response

Application example:

User command: \$08J(cr)
 Module response: !080060 (cr)
 Description: The address 08H module master mode transmission interval is 60 seconds.

13, Set the primary slave mode command

Command functions: setting the target module master mode or slave mode.

Command syntax: \$ AASN (cr)

Parameters:
 \$ delimiter.
 AA target module address range 00H ~ FFH.
 S Set the communication protocol command keyword.

	N	1 for the host mode, 0 for slave mode.
	(Cr)	terminator, host computer Enter key (0DH).
Response syntax:	!AA(cr)	command is valid
	? AA (cr)	command is invalid or illegal operation
Parameter Description:	!	delimiter, indicating that the command is valid.
	?	Delimiter, indicating that the command is invalid.
	AA	represents the target module address.
	(Cr)	terminator, Host computer enter key (0DH)

Other notes: If address error or communication error, the target module will not response.

Application Example 1:

User Commands: \$00S1 (cr)

Module response: 00 (cr)

Description: set the target module for the host mode.

14 read the master slave mode command

Command: Read the target module master mode or slave mode state.

Command syntax: \$AAH (cr)

Parameters: \$ delimiter.
 AA target module address range 00H ~ FFH.
 H read master mode or slave mode status command keyword.
 (Cr) terminator, the host computer Enter key (0DH).

Response syntax: !AA (N) (cr) Command is valid

? AA (cr) command is invalid or illegal operation

Parameter Description: ! delimiter, indicating that the order is in force.

? Delimiter, indicating that the command is invalid.

AA represents the target module address.

(N) 1 host mode, 0 for slave mode.

(Cr) terminator, the host computer Enter key (0DH).

Other notes: If a syntax error or communication error or address does not exist, the module does not respond.

Application examples:

user commands: \$ 08H (cr)

Module response: ! 081 (cr)

Note: The address 08H modules is the host mode.

The input range and data format:

There are 3 data format which are been used by analog input module:

00: (Engineering Units)

01: (% of FSR)

10: hexadecimal (complement)

Input range	Data format	Span +	Zero	Span -	Res.
A1: 0-1mA A5: 0-±1mA	Engineering Unit	+1.0000	±0.0000	-1.0000	0.1uA
	% of FSR	+100.00	±000.00	-100.00	0.01%
	complement hexadecimal of	7FFFFFFF	000000	800000	1LSB
A2: 0-10mA A6: 0-±10mA	Engineering Unit	+10.000	±00.000	-10.000	1uA
	% of FSR	+100.00	±000.00	-100.00	0.01%
	complement hexadecimal of	7FFFFFFF	000000	800000	1LSB
A3: 0-20mA A4: 4-20mA A7: 0-±20mA	Engineering Unit	+20.000	±00.000	-20.000	1uA
	% of FSR	+100.00	±000.00	-100.00	0.01%
	complement hexadecimal of	7FFFFFFF	000000	800000	1LSB
U1: 0-5V U5: 0-±5V	Engineering Unit	+5.0000	±0.0000	-5.0000	0.1mV
	% of FSR	+100.00	±000.00	-100.00	0.01%
	complement hexadecimal of	7FFFFFFF	000000	800000	1LSB
U2: 0-10V U6: 0-±10V	Engineering Unit	+10.000	±00.000	-10.000	1mV
	% of FSR	+100.00	±000.00	-100.00	0.01%
	complement hexadecimal of	7FFFFFFF	000000	800000	1LSB
U3: 0-75mV	Engineering Unit	+75.000	±00.000	-75.000	1uV
	% of FSR	+100.00	±000.00	-100.00	0.01%
	complement hexadecimal of	7FFFFFFF	000000	800000	1LSB
U4: 0-2.5V	Engineering Unit	+2.5000	±0.0000	-2.5000	0.1mV
	% of FSR	+100.00	±000.00	-100.00	0.01%
	complement hexadecimal of	7FFFFFFF	000000	800000	1LSB
U7: 0-100mV	Engineering Unit	+100.00	±000.00	-100.00	0.01mV
	% of FSR	+100.00	±000.00	-100.00	0.01%
	complement hexadecimal of	7FFFFFFF	000000	800000	1LSB
A8: customized U8 : customized	Engineering Unit	+100.00	±000.00	-100.00	0.01%
	% of FSR	+100.00	±000.00	-100.00	0.01%
	complement hexadecimal of	7FFFFFFF	000000	800000	1LSB

Table 4 input range and data format

Note: DS18B20 temperature value, a sign bit, three integer bits, and two decimal digital display, such as +020.05, -010.25, respectively, are 20.05 ° C and a negative 10.25 ° C.

E.g.:

1、input range is $\pm 20\text{mA}$, output is 4 mA:

user command	#01(cr)
Engineering Unit Module response	>+04.000(cr)
% of FSR Module response	>+020.00(cr)
complement of hexadecimal Module response	>199999(cr)

2、output range is $\pm 10\text{V}$, output is 2.5V

User command	#01(cr)
Engineering Unit Module response	>+02.500(cr)
% of FSR Module response	>+025.00(cr)
Complement of hexadecimal Module response	>1FFFFFF(cr)

3、conversion relation between hexadecimal data and analog

Using 24 bits AD converting clips improves the precision of the product greatly. The analog is converted to be hexadecimal data by AD clips as the following formula shows.

$$\frac{X}{7FFFFFFF} = \frac{I_{in}R_0}{I_mR_0}$$

Instructions: X: represents the corresponding hexadecimal data of the analog.

I_{in}: represents the analog signal the channel input.

I_m: represents the analog of the scale span of product, 20mA.

R₀: represents sampling resistor.

Data read by the RTU is the high-volume four hexadecimal data of conversion. In the calculation of the value of the corresponding data in engineering units, it is necessary to fill the last two hexadecimal data 00 (set as six bits hexadecimal data), otherwise the results might not be accurate. If needs to view all the six bits hexadecimal data, the user could select the complement hexadecimal form in the output data format.

For example, if the user checked the data is 1999 on 4001 register by Modbus software, the calculation process is as follows:

1. after the complement, the 6 bits hexadecimal data of 1999 is 199900.
2. Convert 199900 and 7FFFFFFF into decimal data.
3. Calculate the I_{in} value of analog input
4. Voltage output: I_{in}R₀ is V_{in} (voltage input value of the channel), I_mR₀ is full scan voltage input value.
5. If the voltage and current value is minus, user could calculate the related analog value according to the above formula.

Mode Calibration

The product has been calibrated before delivery, and the user can directly use it without calibration.

The user could recalibrate the module via the calibration function of the product. During the calibration, analog input module needs to be connected with the appropriate input signal on the channel which as to be calibrated. Different input range requires different input signal.

In order to improve calibration accuracy, it is recommended to use the following equipment:

- 1, a stable output, low noise DC voltage / current signal source
- 2, one five and a half bits or a higher-precision voltage / current measuring instruments to monitor the accuracy of the input signal

The calibration process

1. Select the input channel to be calibrated and connect to the corresponding input signal according to the input range of the module

Zero is calibrated when the input is 0; full scan is calibrated when input 120% of FSR. For example, when the input is 4-20mA, zero calibration: 0mA input; full scan calibration: 24mA. When the input is 0-5V, zero calibration: 0V input; full scan calibration: 6V.

2. Input zero signal to the channel, usually it is 0mA or 0V.
3. When the signal is stable, send offset calibration \$ AA1N command (N represents the channel code currently being calibrated, 0 or 1) to the analog input module.
4. Input current or voltage signal of 120% of FSR to the channel which needs calibration.
5. When the signal is stable, send gain calibration \$ AA0N command (N represents the channel code currently being calibrated) to the analog input module.
6. Calibration is finished.

Modbus protocol

Modbus protocol defines the information structure which could be identified and used by controller. When communicating on the Modbus network, the protocol allows each controller to know its own device address, and identify the data addressing to it, then decide the effective type and take out data contained in the information. The controller can also organize the response information and use the Modbus protocol to send out this information.

The controller takes use of master-subordinate technique. That is to say, only one device (the master) can initiate transmission (the query), and other devices (subordinate ones) respond according to data queried by the master device. A typical master device: host and programmable instrument. Typical subordinate device: programmable controllers.

Master device can communicate with one subordinate device, but also communicate with all subordinate devices by broadcast. For the former situation, the device will respond one message; for the latter, the device will not respond. Modbus protocol establishes a master query format: device (or broadcast) address, function code, all the data to be sent, and an error detection field.

Response message of subordinate device is also constituted by the Modbus protocol, including the domain to be act, any data to be returned, and an error detection field. If a error occurred during message reception, or the subordinate device can not perform its command, the subordinate device will create an error message and sent it out as a response

Modbus has two means of transmission: ASCII and RTU

Communication in ASCII mode, each 8 bit byte in a message is sent as two ASCII character. It uses the LRC error detection, the advantage of which is that the interval of sending the character is only 1s without error; while in RTU mode, every 8 bit byte contains two 4 bit of hexadecimal characters. It uses the CRC error detection, and the advantage is at the same baud rate, it can transmit more data than ASCII.

About ASCII mode and RTU data format, more information can be found in the relevant Modbus communication protocol:

	ASCII mode	RTU mode
Code system	hexadecimal, ASCII character 0~9, A~F every ASCII byte consists of one hexadecimal character	8 bit binary system, hexadecimal 0~9, A~F Every 8 bit consists of one or two hexadecimal character
Data bit	1 start bit 7 data bits, the smallest significance bit significance bit sent firstly 1 parity check bit, none if there is no calibration 1 stop bit (with calibration), 2 Bits (without calibration)	1 start bit 8 data bits, the smallest significance bit significance bit sent firstly 1 parity check bit, none if there is no calibration 1 stop bit (with calibration), 2 Bits (without calibration)
Error detection	LRC (Longitudinal rigmarole check)	CRC (circulate rigmarole check)

1、 set Modbus RTU mode

The device use ASCII command set as default protocol. To use MODBUS RTU, follow these steps to set:

1. Short circuit CONFIG (the 3rd pin) and GND (the 4th pin)
2. Correctly link Power and other interface cables
3. Switch on power supply, module is in default state automatically, communication address is 00, baud rate is 9600.
4. The module is to finish initialization, about 5 minutes
5. Send command \$00P1 (cr), check response, if it is !00(cr), set correctly.
6. Switch off power supply, cut off the connecting between CONFIG and GND
7. Module has been set to MODBUS RTU protocol

Data format under MODBUS RTU

Host query message specifies the start address of the register to be read and the quantity of registers. The start address of the register addressing is 0000. Checking format is as following:

Slave Address	Function	Starting Address Hi	Starting Address Lo	No. of Points Hi	No. of Points Lo	Error Check(CRC)
01	03	00	00	00	08	44 0C

Host send query information Tx: 01 03 00 00 00 08 44 0C

01 device address

03 function code

00 00 the start address of register addressing

00 08 quantity of register

44 0C CRC check code

Subordinate device response

Register data in the response information of subordinate device corresponds to the two bytes of each register; the first data byte is high, the second is the low data. Response format is as following:

Slave Address	Function	Byte Count	Data Hi(Register 40001)	Data Lo(Register 40001)	Data Hi(Register 40002)	Data Lo(Register 40002)	Data Lo(Register 40008)	Error Check(CRC)
01	03	10	19	99	00	00	02	9E 68

Subordinate device response information Rx: 01 03 10 19 99 00 00 00 00 00 00 00 00 00 04 00 00 00 87 69

01 device address

03 function code
 10 the quantity of bytes
 19 99 the first register data
 00 00 the second register data

87 69 CRC check code

The below Table is the register information checked by MODSCAN software and its instruction

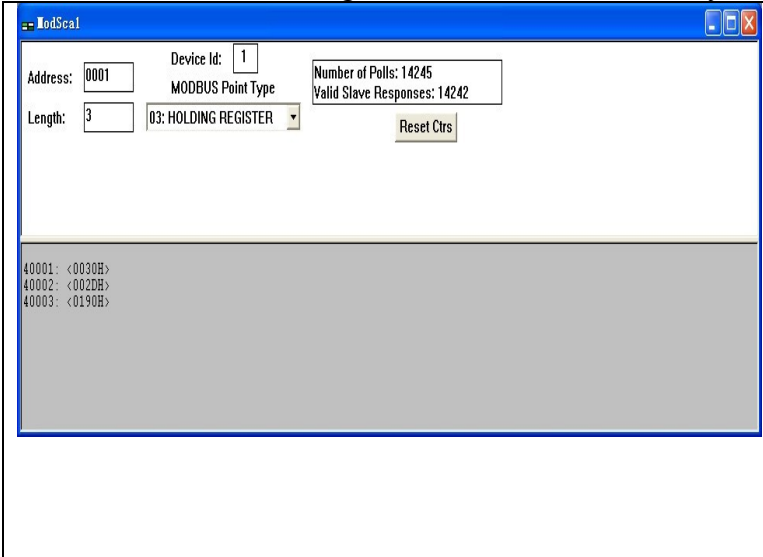
 <p>The screenshot shows the ModScan software interface. At the top, there are fields for 'Address' (0001), 'Device Id' (1), 'MODBUS Point Type' (03: HOLDING REGISTER), 'Number of Polls' (14245), and 'Valid Slave Responses' (14242). A 'Reset Ctrs' button is also visible. Below these fields, a list of registers is displayed: 40001: <0030H>, 40002: <002DH>, and 40003: <0190H>.</p>	<p>Instructions:</p> <p>Address is the start address of the register Device ID is module address Length is the number of registers been read MODBUS Point Type :Modbus function type selection 40001: corresponds to register data, analog input value of channel 0 40002: corresponds to register data, analog input value of channel 1</p>
--	--

4、Instructions of register:

Address	Data	R/W	Description
4X			
40001	IN0	Read only	Measured Value of Channel 0
40002	IN1	Read only	Measured Value of Channel 1
40003	DQ	Read only	DS18B20 collected temperature value (16 hex, MSB first).
40004	IN3	Read only	Measured Value of Channel 3
40005	IN4	Read only	Measured Value of Channel 4
40006	IN5	Read only	Measured Value of Channel 5
40007	IN6	Read only	Measured Value of Channel 6
40008	IN7	Read only	Measured Value of Channel 7
40211	Module Name	Read only	Higher bits: 0x01 Lower bits: 0x08
40221	Channel Status	Read/Write	Higher bits: 0x00 Lower bits: Channel Status (0x07)

Table 5 Modbus Rtu registers Instructions

Note: For information the DS18B20 collected temperature to be converted to the corresponding decimal value, please refer to the DS18B20 data sheet.

Dimension: (unit: mm)

